



Operating Instructions

Issue no.
Sheets

1
21



Creasing, Perforating and Punching Machine GPM 450 verSA

Attention

This document including its appendices is the exclusive intellectual property of Cyklos Choltice, Producer Cooperative. Any other use (copying, distribution or sale) is possible only with the approval of the chairman of the cooperative.

Valid from serial number:

201929297

Content

1. Introduction.....	3
2. Safety Risks.....	3
2.1 Warning.....	3
2.2 General Work Safety and Health Protection.....	3
3. Warnings and Recommendations	4
4. Technical Parameters	5
5. Machine Description	6
5.1 Introduction.....	6
5.2 Exchangeable tools.....	7
6.1 Adjustment of Top Bar Stroke.....	8
7. Setting the Machine Using Touch Screen.....	9
7.1 Overview of Touch Screen Function Icons	9
7.1.1 Sound On/Off	9
7.1.2 Manual Control.....	9
7.1.3 Info.....	10
7.1.4 Language Selection.....	11
7.1.5 Speed of Processing.....	11
7.1.6 Service Menu	11
7.2 Setting the Number and Position of Creases/Perforations.....	12
7.2.1 Crease Positon – Manual Setting.....	12
7.2.2 Crease Position – Automatic Setting.....	13
7.3 Program Saving and Loading	14
8. The Most Common Faults (Troubleshooting)	15
9. Recommended Machine Maintenance	15
10. Machine Disposal	15
Appendix 1: Accesories.....	16
Appendix 2: Optional Accessories	19

1. INTRODUCTION

We are presenting you with Operating Instructions that contain machine technical data and instructions necessary for the correct setting, start-up, operation, and maintenance of the machine.

The Operating Instructions are intended for machine operators as well as for service engineers. The individuals manipulating, installing and operating the machine should familiarise themselves with the instructions before they start. We would like to emphasize that service operations may only be executed by authorized individuals with proper qualifications. They should be thoroughly familiar with the control and all functions of the machine. Any repair done without authorization may render the warranty null and void. Reference is made to Section 2.2 – Work Safety and Health Protection providing basic information about the safe use of the machine and operator's health protection. Please pay due attention to this section. Be aware that the final responsibility lies with the individuals working with the machine.

The machine construction complies with Directive 98/37/EC of the European Parliament and of the Council. If all the instructions in this document are respected, the machine will render satisfactory and precise performance.

We can assure you that the machine has received maximum care. The thoroughness of control ensures machine precision within the scope of the acceptance standards applicable to this machine. We believe these Operating Instructions will be a valuable guide for you.

2. SAFETY RISKS

2.1 Warning

When using the GPM 450 verSA, all safety rules and procedures, as well as all warnings regarding work safety and health protection listed in this document, must be observed. Otherwise, considering the bellow listed factors, a serious injury or death of a person, damage or destruction of the machine, its parts or accessories could occur.

Factors increasing risk:

- Rotating pulleys and moving belts
- Voltage
- Noise made during processing
- Moving parts of the machine and equipment
- Sharp edges created during processing
- Dust created during processing

2.2 General Work Safety and Health Protection

This section provides the user with basic information about workplace safety and health protection of the operator and any other individuals who come into contact with the machine.

If the GPM 450 verSA is used correctly, it is a very safe machine. However, if used incorrectly, it can be dangerous. When operating the machine, the operator is responsible for their own personal safety. The manufacturer may not be held liable for any personal injury or damage to the machine caused by use or operation at variance with these Operating Instructions. The owner of the machine is responsible for the machine being operated, maintained and serviced only by qualified personnel.

The machine design is in compliance with international standards and regulations for the construction of machine tools. For the machines exported to the European Economic Area (EEA), the customer will obtain a "**Declaration of Conformity**" together with the accompanying technical documentation for the machine - Operating Instructions. Also, the machine bears the CE marking.

The CE marking on the machinery signifies that the product complies with the technical requirements specified in all the legal regulations that apply to the machinery and that require or allow this marking. This marking also signifies that a specified procedure was followed during the assessment of the stated conformity.

The manufacturer certifies by means of the "Declaration of Conformity" that the machinery concerned complies with the requirements of Directive 98/37/CE of the European Parliament and of the Council and those of the harmonized technical standards. Directive 98/37/CE of the European Parliament and of the Council is a document defining the generally applicable basic requirements for health protection and safety of machinery operated at the user's facility within the EEA.

Directive 98/37/CE of the European Parliament and of the Council does not apply to the machinery exported to countries outside the EEA.

The customer will receive the accompanying technical documentation for the machine – Operating Instructions. The manufacturer hereby requests that the user trains its staff accordingly in order to ensure comprehensive safety as directed by the relevant laws, standards and regulations, these Operating Instructions and other documents.

The machine is intended for work in automatic cycles.

The machine operator monitors the process and the operating mode of the machine, replacing material and checking the dimensions. The Operator's position by the machine is not defined.

3. WARNINGS AND RECOMMENDATIONS

Only sheets of the size listed in the parameters can be creased, perforated and punched by GPM 450 verSA.

- a) The operator or the individual appointed for operation cannot use the machine unless they have been trained.
- b) Only sheets of the size listed in the parameters can be creased, perforated and punched by GPM 450 verSA.
- c) It is forbidden to crease and perforate foils, sheet metal or other similar materials.
- d) The machine can be only used in interior spaces (e.g. offices, shops), it is not allowed to use the machine outdoors.

- e) It is forbidden to use the machine when the electric cord is damaged.
- f) It is forbidden to use the machine if it makes strange sounds.
- g) It is forbidden to connect the machine to voltage different from that indicated on the manufacturer's identification plate.
- h) Read all instructions before using the machine.
- i) Keep the children away from the machine.
- j) It is forbidden to put fingers or hands into the machine when the electric cord is plugged in.
- k) Covers can be only dismantled by trained personnel when the machine is unplugged.
- l) Do not replace faulty electrical components with components of different type or different capacity. When replacing a component, the electric cord must be unplugged.

4. TECHNICAL PARAMETERS

a)	Working width	450 mm
b)	Recommended paper grammage	80 – 400 gsm (creasing, punching) 80 – 250 gsm (perforating)
c)	Crease width	CITO 1.0 mm – paper thickness < 0.4 mm (recommended grammage 80 – 200 gsm) “Iron Channel” 1.9 mm – paper thickness 0.4 – 0.5 mm (recommended grammage 200 – 400 gsm)
d)	Max. number of creases per sheet	15
e)	Number of programs	15
f)	Min./max. distance between creases	1/999 mm
g)	Speed	1.500 sheets A4/h (with single crease)
h)	Machine dimensions	1.075 x 635 x 390 mm
i)	Packing size	740 x 530 x 675 mm
j)	Weight	Nett 77 kg, Gross 81 kg
i)	Voltage / Frequency	230V / 50Hz – 0,5A 110V / 60Hz – 0,7A (USA)

5. MACHINE DESCRIPTION

5.1 Introduction

The GPM 450 verSA is a creasing, perforating and punching machine where the parameters of individual operations are entered on the touch screen. Loading the sheet of paper is manual, but the feed of each paper is already done by a stepper motor. The creasing allows for easy folding of the paper, whereas waste-free perforation allows you to tear off the paper easily.

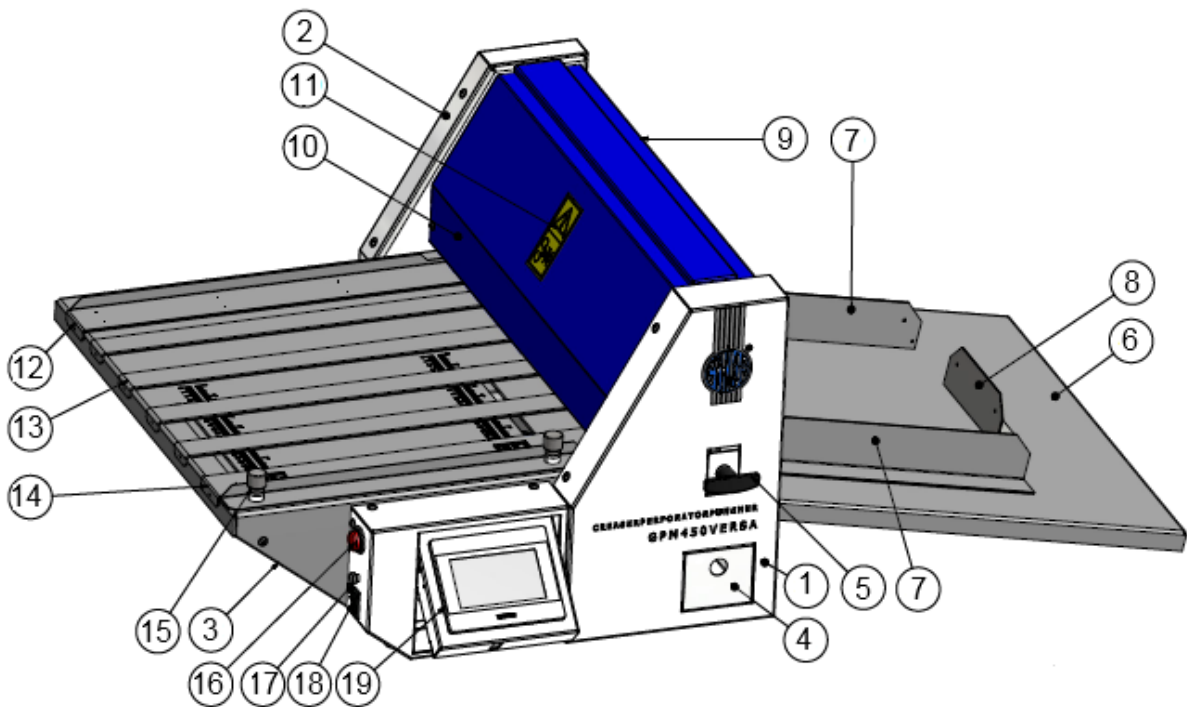

Fig. 1: View of the machine – right side

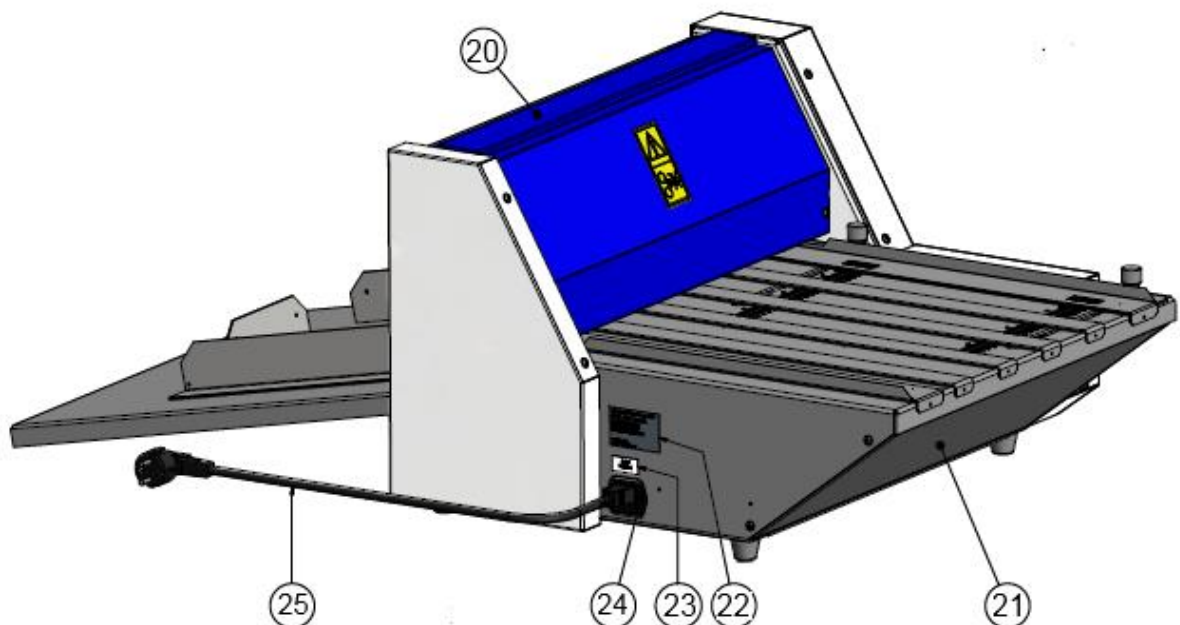

Fig. 2: View of the machine – left side

Position	Name	Position	Name
1	Right Cover	14	Front Right Guide
2	Left Cover	15	Side Guide Lock
3	Front Table	16	STOP Button
4	Waste Drawer	17	Tilt Display Button
5	Exchangeable Tool	18	Main Switch
6	Delivery Table	19	Display (Touch Screen)
7	Rear Side Guide	20	Upper Cover
8	Back Stop	21	Front Bottom Cover
9	Rear Tilt Cover	22	Production Label
10	Front Tilt Cover	23	Fuse Label
11	Warning Sign	24	Plug Socket
12	Front Left Guide	25	Power Cable
13	Levelling Strip		

5.2 Exchangeable Tools

In standard equipment, the machine is supplied with the three exchangeable tools described below. The default setting has been done for all types of tools. A change of the machine function requires the tool to be replaced. Creasing tools are placed by the manufacturer into the Waste Drawer (4).

Loosen the tool screws (11, 12, 13, 14, 15) in order to replace the knives in the tools. Replace the knife and fit the tool back. Tighten the tool screws (11, 12). **Do not overtighten the tool screws (13, 14, 15).** Then place the tool into the machine and perform a trial stroke (see Section 6.1) to ensure the knife and the tool base is parallel (1). Now tighten the screws (31, 32) completely. Now the tool is ready for use.

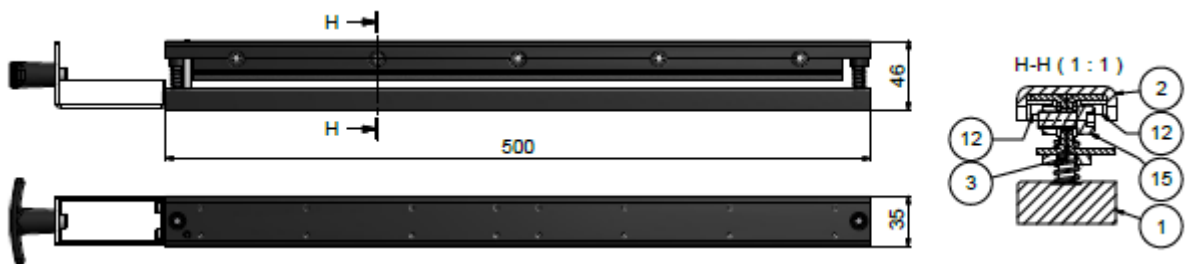

Fig. 3: Creasing tool CITO 1.0 mm (571 40 467) – standard equipment. Creasing tool CITO 1.4 mm (571 40 468) as optional accessory.

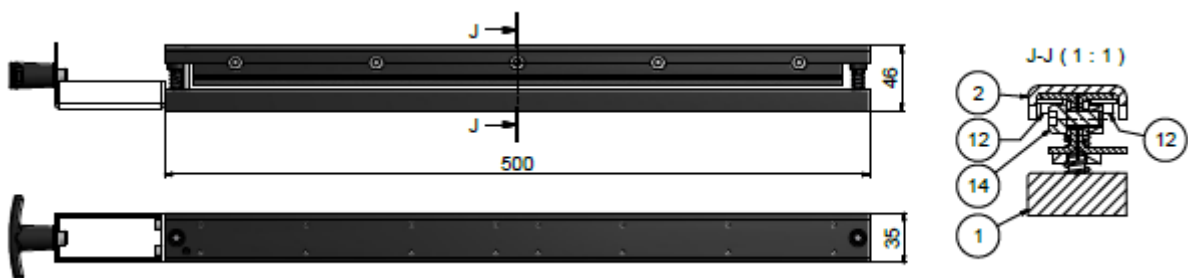

Fig. 4: Creasing tool – iron channel 1.9 mm for heavy grammage (570 40 466)





Fig. 5: Perforating tool 2:1- 9 TPI (571 40 465a) – standard equipment. Micro perforating tool (571 40 464) as optional accessory.

Pozn.: The list of optional tools can be found in the end of this document – [Appendix 2: Optional Accessories](#)

6. MACHINE INSTALLATION

After unpacking, place the machine on a flat firm surface and attach the Delivery Table (6). Connect the machine to the power supply, after that the machine is ready for operation. The perforation function is factory set. For the creasing function replace the tool included in the packaging (Section 5.2).

6.1 Adjustment of Top Bar Stroke

Unless the depth of a crease on both sides of the sheet is identical or unless the sheet is torn away evenly after perforation, the top bar can be moved down using the tool thrust regulation screws. The screws should be loosened anticlockwise by approx. 30°, 1/12 of the revolution (the bar moves downward) and then secure them with a nut. Try the quality of perforation after each turn of the screw by 30° and, if satisfactory, do not turn the screws anymore. When the adjustment of perforation is finished, the machine is also to be adjusted for creasing. If the perforating/creasing force exceeds the limit (engine output is exceeded) and the top bar remains in the lower position, use the Main Switch (18) to switch the machine off and then wait for 20 seconds before you re-start the machine. Press  (Manual control – Section 7.1.2), then  (tool backward) next to the field **UPPER TOOL**. The tool is now unlocked and the thrust can be adjusted using the tool thrust regulation screws. Activate  (tool forward) to make a trial stroke.

7. SETTING THE MACHINE USING TOUCH SCREEN

When the machine is switched on with the Main Switch (18), the Home Screen appears on the display.

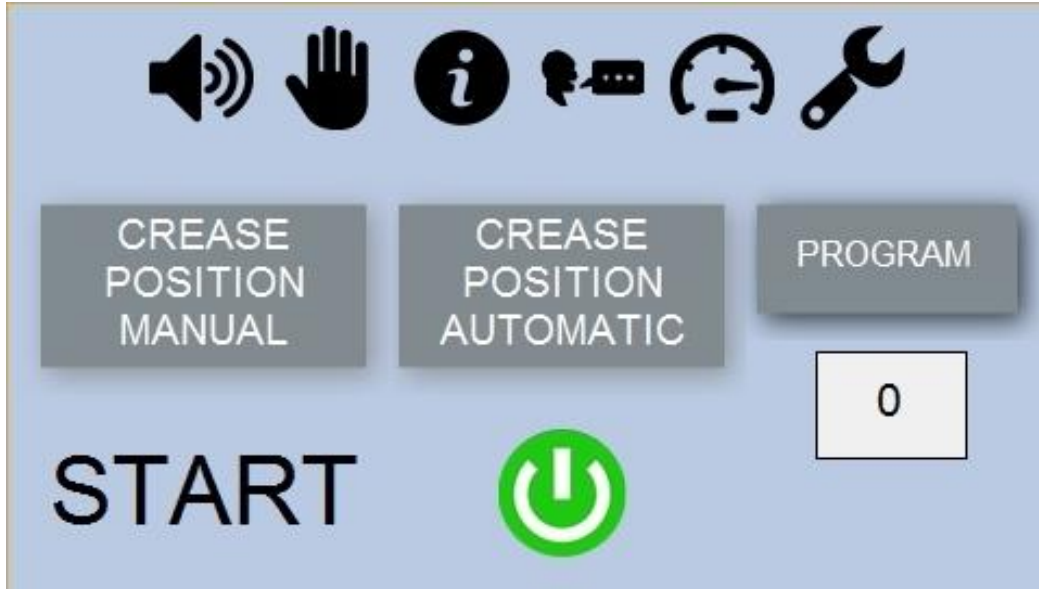



Fig. 6: Home Screen

7.1 Overview of Touch Screen Function Icons

7.1.1 Sound On/Off

Press  to turn on/off the sound signal for key pressing. If the sound is on, there will be a beep when the active areas on the touch screen are pressed. If the sound is off,  appears.

7.1.2 Manual Control











Manual control is mostly used when replacing the tools or when loosening jammed paper from the machine. Press  (manual control) on the Home Screen (Fig. 6) and the following menu is displayed (Fig. 7). Press the move forward/backward icons ,  next to the **MOVE ROLLERS** field to set the machine's rollers running. Icons  and  define the continuity of the run of the rollers.  – rollers are turning only if the arrow is held.  – rollers start running and rotate until the icon is pressed again. Use  (tool backward) next to the **UPPER TOOL** field if the perforation/creasing force gets too high and the top bar remains in the lower position. Press  to unlock the tool and adjust the thrust by using the tool thrust regulation screws. Activate  (tool forward) to make a trial stroke. Refer to Section 6.1 for how to use the icons of the **UPPER TOOL** field. Press **OK** to go back to the Home Screen.



Fig. 7: "MANUAL CONTROL" Screen

7.1.3 Info

Press **i** to display the information screen. The data are approximate. Press **OK** to go back to the Home Screen.

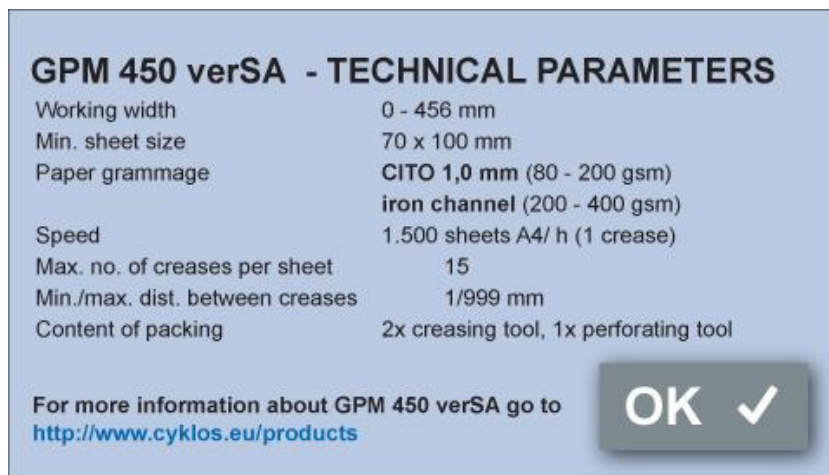

Fig. 8: Information Screen

7.1.4 Language Selection



Press  to display the language selection pop-up menu and choose the language.



Fig. 9: "LANGUAGES" Screen

7.1.5 Speed of Processing

To adjust the speed of processing press  on the Home Screen (Fig. 6). Change speed of rollers rotation using + and – keys. The machine is set for 100 meaning 100% speed of the machine. The minimum value is 50. Lower speeds are suitable for processing papers complicated to feed. When you have finished the setting, press **OK** to confirm.

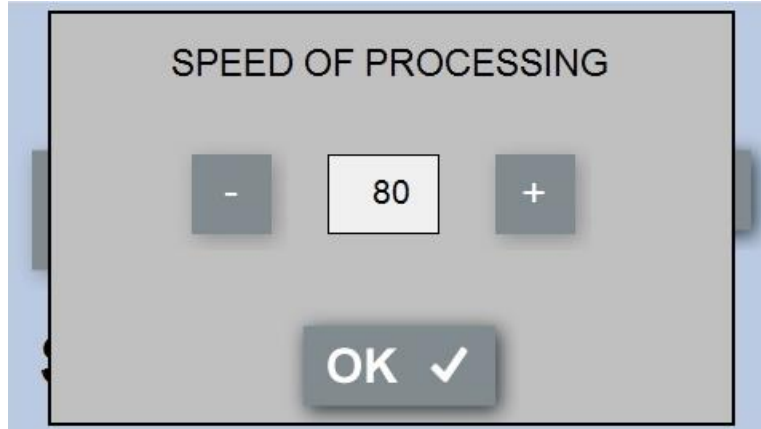



Fig. 10: "SPEED OF PROCESSING" Screen

7.1.6 Service Menu

Press  to display the "SERVICE MENU" screen (Fig. 11a). This menu is password-protected and accessible only to the manufacturer's (distributor's) service engineers. If you do not know the password, press  to return to the Home Screen. Entering the correct password and confirming by **OK** displays the "SERVICE MENU" screen. Press **OK** to go back to the Home Screen.

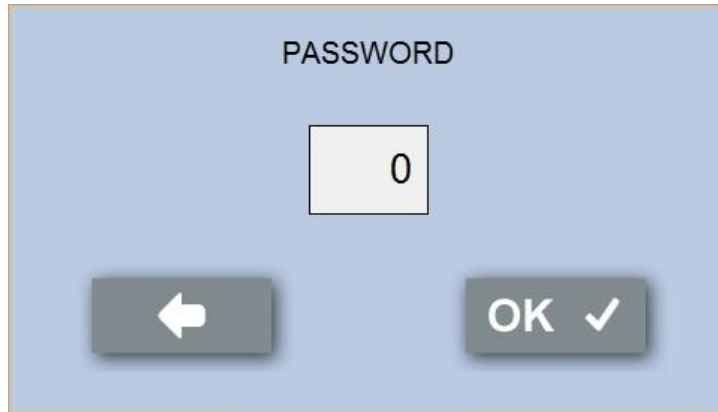

Fig. 11a: "SERVICE MENU" Screen – Password

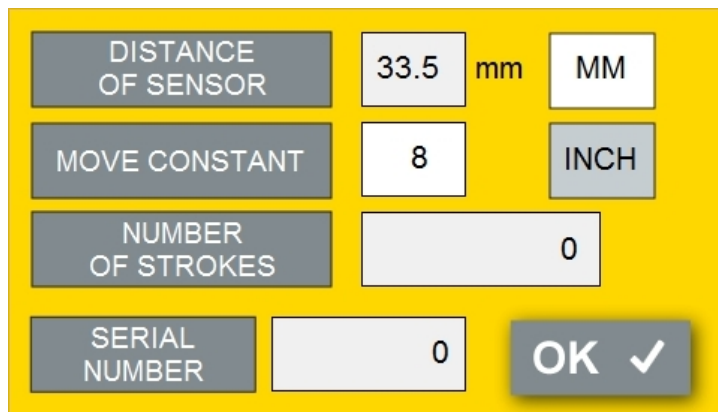

Fig. 11b: "SERVICE MENU" Screen

Note: Description of service screen is not part of this manual because this screen is not accessible to end user.

7.2 Setting the Number and Position of Creases/Perforations

7.2.1 Crease Position – Manual Setting

Press **CREASE POSITION MANUAL** on the Home Screen (Fig. 6) to display the following menu.



Fig. 12: "CREASE POSITION MANUAL" Screen

Press the numeric icon next to the **NO. OF CREASES** field on the touch screen to display the numeric keypad. By pressing the relevant digit, the number of crease/perforation/punch lines (segments) is set. You can set as many as 1 – 15 segments. The selection of the number of segments is ended by pressing the **ENTER** key. The number of segments is now set.

Setting the Position of Segments

The position of the first segment is set as the distance from the edge of the sheet. The position of each following segment is defined as its distance from the previous segment. Use the **+** and **-** keys to choose the required segment. Select 1 in the numeric field next to **CREASE NO.** and this activates the **DISTANCE** numeric icon. A numeric keypad is now displayed. Use the numeric keypad to set the distance from the edge of the sheet and press **ENTER**. The position of the first segment is set. Using the **+** key choose segment number 2 and then press the numeric icon under **DISTANCE** again. Use the numeric keypad to set the distance from the first segment and press **ENTER**. The second segment is set. Set all the remaining segments in the same way.

7.2.2 Crease Position – Automatic Setting

Press **CREASE POSITION AUTOMATIC** on the Home Screen (Fig. 6) to display the following menu.

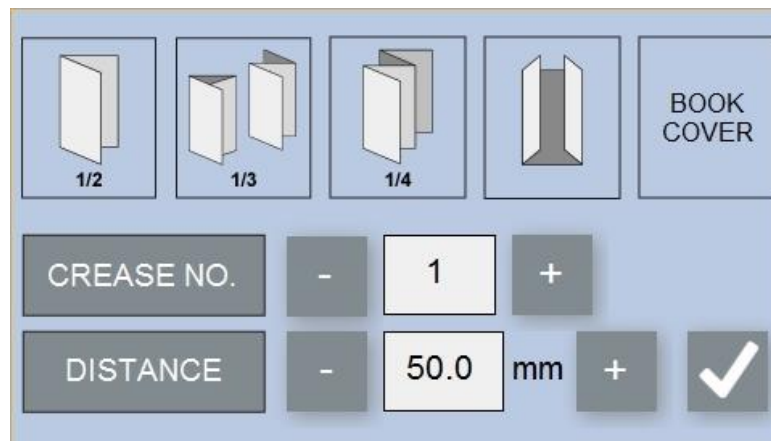



Fig. 13: “CREASE POSITION AUTOMATIC” Screen

The most commonly used folds are created by placing the crease at exactly defined relative distances of the paper like 1/2, 1/3, 1/4, etc. The most common creases are easily set by pressing the corresponding button. First, place the required sheet of paper to be processed on the feeding table. Then press **1/2** (proceed similarly for other types of the fold). A single sheet is run through the machine without processing; the machine measures the sheet (Fig. 12a) and saves the sheet length in the memory. Values are displayed in their respective fields when the sheet has passed through. Make a test. Once the test is completed, it is recommended to check the measured length before processing the rest of the batch. If the crease is not precisely at the required distance, correct the distance manually. Then press the checkmark to return to the Home Screen and press **START**  to run the working process.

Note: One of the predefined fold types is BOOK COVER. It is defined by 4 creases in the middle of the sheet. After pressing this icon pop-up menu appears allowing you to set the width of the hinge and width of the edge of the book cover.

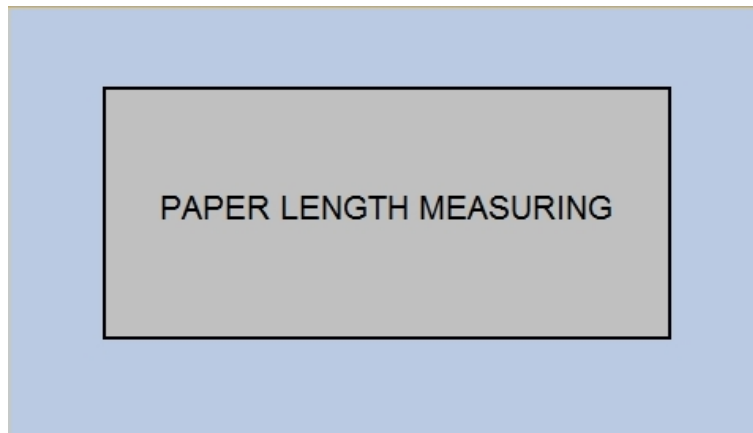

Fig. 13a: "PAPER LENGTH MEASURING" Screen

7.3 Program Saving and Loading

The software allows saving 15 different programs. Press the numeric key under the field **PROGRAM** on the Home Screen. The program saving and loading menu (Fig. 14) is displayed. Use the + and - keys to list values between **1** and **15**. You can save your jobs under **1 – 15**.

Press **SAVE** if you have your job ready and wish to save it. It is possible to name a job you wish to save. The name changes along with the program number. Load the program in a similar manner. Use + and - to choose a saved program you wish to load. Press **LOAD**. Press **OK** to go back to the Home Screen. The number of the loaded program is displayed under the **PROGRAM** field. The machine is ready to operate according to this program.

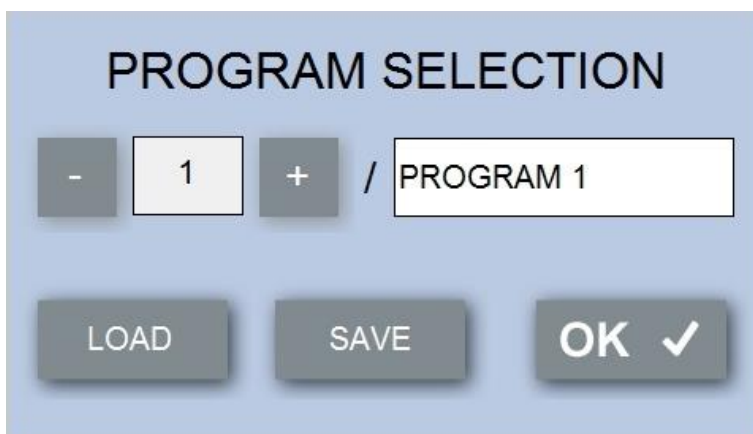

Fig. 14: "PROGRAM SAVING AND LOADING" Screen



Warning: The touch screen displays the number of the last program saved or loaded. For the sake of effectiveness, the operator can change this program by a different program without saving it. In such case, the number of the last program saved or loaded is still displayed, but the machine operates according to the operator's last setting, even though this setting has not been saved. If the machine is turned off and then turned on again by the electric switch, the machine operates according to the program displayed on the touch screen. The last unsaved setting is deleted.

8. THE MOST COMMON FAULTS (TROUBLESHOOTING)

a) Upper Tool blocked:

If the upper tool gets stuck when adjusting and testing the stroke depth, first loosen the lock nuts and then turn the adjusting screws clockwise up to 2 turns (the upper tool moves upwards). When the stroke cycle is interrupted, the LED lights up red. An interrupted stroke cycle should be completed after starting the machine. The upper tool must be readjusted.

b) Paper Jam:

If paper is jammed or damaged in the machine during operation, the machine must be switched off immediately by the STOP button. After stopping the machine, select the  Manual control. Before ejecting the paper, it is necessary to perform one control stroke of the tool (the upper tool may be in the lower position). Then we can use the icons  "Forward" or  "Back".

c) The position of the crease on the paper is not in accordance with the values shown on the display

Exceeding the recommended creasing values, meaning using CITO tool 1.0 mm for too thick paper may cause inaccuracies. The position of the crease on the paper will not match the values shown on the display. The inaccuracy is due to the thick paper being pressed into the narrow groove and the subsequent feed rollers slipping while trying to pull the pressed paper out of the groove. In this case, an iron tool with 1.9 mm wide groove must be selected.

9. RECOMMENDED MACHINE MAINTENANCE

Clean dust from the machine after each job using, for example, compressed air.
Grease the bearings with bearing grease annually.

10. MACHINE DISPOSAL

After the end of the service life, it is forbidden to dispose of the machine in the municipal waste. The machine must be disassembled, and metallic, non-metallic, plastic, rubber and electronic parts sorted. These parts are disposed of at the relevant points of recycling. Some parts of the machine can contain hazardous substances that are harmful to the environment and health.

APPENDIX 1: ACCESORIES

571 40 467	Creasing Tool (CITO channel 1.0 mm)	1 x
571 40 466	Creasing Tool – “Iron Channel” 1.9 mm	1 x
571 40 465a	Perforating tool 2:1	1 x



A perforating tool (571 40 465a) is fitted in the machine for transit. Creasing Tool CITO 1.0 mm (571 40 467) and Creasing Tool – “Iron Channel” 1.9 mm (571 40 466) are kept in the waste drawer (4).



Note: The tools for GPM 450 verSA, GPM 450 SPEED and AirSpeed 450 are identical. Only AirSpeed 450 is wider, a small metal-sheet extension needs to be fitted on this tool; the extension is kept in the waste drawer, see the picture.

574 46 978

DELIVERY TABLE (6)

1x



574 59 577

BACK STOP (8)

1x

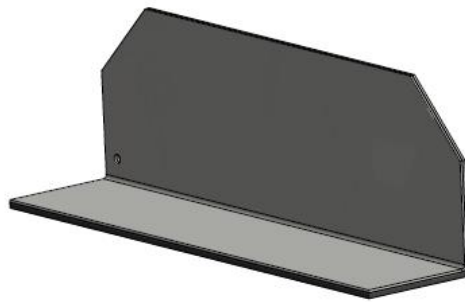

574 59 563

REAR SIDE GUIDE (7)

2x

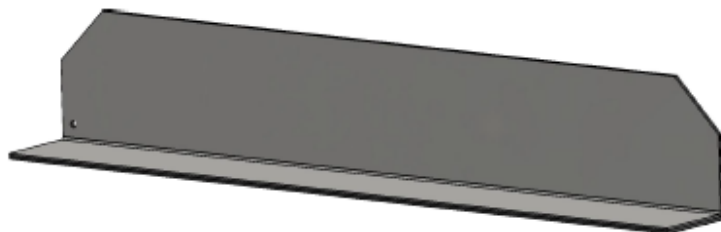

574 59 490

FRONT LEFT GUIDE (12)

1x

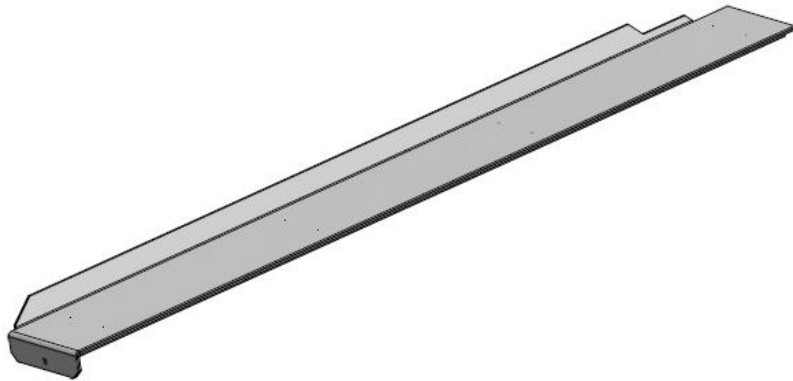

574 59 496

LEVELLING STRIP (13)

4x

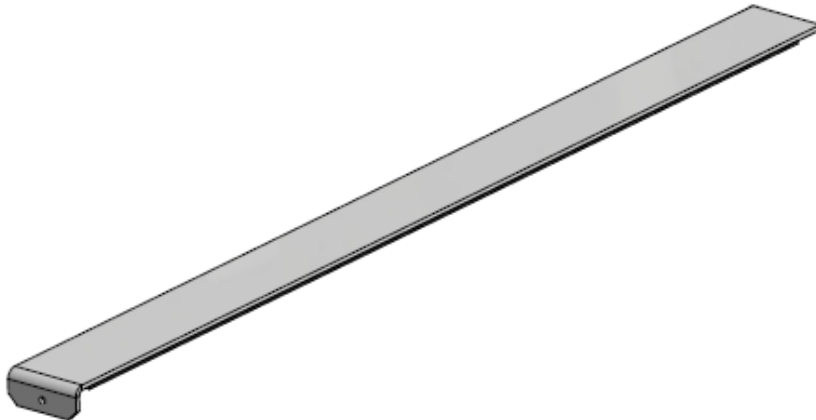

413 00 008/0 ALLEN KEY NO. 5

1x



345 00 226/0

POWER CABLE

1x



APPENDIX 2: OPTIONAL ACCESSORIES

Punching tool for wire binding – square 4 x 4 mm, 3:1 (571 40 462)



Punching tool for wire binding – square 5 x 5 mm, 2:1 (571 40 529)



Punching tool for wire binding – square 6 x 6 mm, 2:1 (571 40 593)



Punching tool for wire binding – round, diameter 4 mm, 3:1 (571 40 475)



Punching tool with calendar semi-circle – square 4 x 4, 3:1 (571 40 463)



Punching tool with calendar semi-circle – round, diameter 4 mm, 3:1 (571 40 476)



Punching tool for coil binding – oval 4 x 5 mm (571 40 594, 571 40 609, 571 40 625)



Punching tool rectangle - 21 holes, 3x8 mm (571 40 624)



Micro perforating tool 30 TPI (571 40 464)

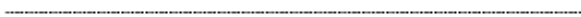

Partial perforating tool (571 40 571)

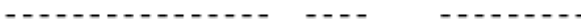

Removing punching tool pins

All the punching tools specified above, have removable pins. To remove the pins, loosen the 10 screws on the upper edge of the tool and remove the bar under the screws. After you have removed the bar, use pliers to take each pin out. Then put the bar back in the original position and replace the screws.



Note: For technological reasons, each machine tool features two pin types of different lengths (the approximate length difference is 0.5 mm). When you have removed the pins, make sure you mark which pin is fitted in which hole so that you can fit the pins back in the correct holes. If you fit a pin in the wrong hole, the passage of the pin through the paper may become impaired.